



Electrical Specifications

Ranges and Resolution

abs: Absolute reference (atmospheric pressure to zero at full vacuum)

vac: Vacuum gauge, minus sign not used unless specified

Resolution is fixed as indicated in table below

Contact factory for engineering units not listed

-30.0 inHg/15.0 psig	120.0 inHg	1600 mmHg	35.0 bar	1.000 kg/cm ² abs
-30.0 inHg/100.0 psig	199.9 inHg abs	760 torr abs	70.0 bar	1.000 kg/cm ² vac
-30.0 inHg/199.9 psig	199.9 inHg	1600 torr abs	140.0 bar	±1.000 kg/cm ²
3.00 psig	50.0 oz/in ²	2100 mmH ₂ O	199.9 bar	1.000 kg/cm ²
5.00 psig	80.0 oz/in ²	3500 mmH ₂ O	350 bar	1.999 kg/cm ² abs
15.00 psi abs	240 oz/in ² abs	199.9 cmH ₂ O	19.99 kPa	1.999 kg/cm ²
15.00 psig vac	240 oz/in ² vac	350 cmH ₂ O	35.0 kPa	4.00 kg/cm ²
±15.0 psig	±240 oz/in ²	1000 cmH ₂ O	100.0 kPa abs	7.00 kg/cm ² abs
15.00 psig	240 oz/in ²	2100 cmH ₂ O	100.0 kPa vac	7.00 kg/cm ²
30.0 psi abs	85.0 inH ₂ O	199.9 mbar	±100.0 kPa	14.00 kg/cm ²
30.0 psig	140.0 inH ₂ O	350 mbar	100.0 kPa	19.99 kg/cm ²
60.0 psig	400 inH ₂ O abs	1000 mbar abs	199.9 kPa abs	35.0 kg/cm ²
100.0 psi abs	400 inH ₂ O vac	1000 mbar vac	199.9 kPa	70.0 kg/cm ²
100.0 psig	±400 inH ₂ O	±1000 mbar	400 kPa	140.0 kg/cm ²
199.9 psig	400 inH ₂ O	1000 mbar	700 kPa abs	199.9 kg/cm ²
300 psig	850 inH ₂ O	1999 mbar abs	700 kPa	350 kg/cm ²
500 psig	7.00 ftH ₂ O	1999 mbar	1500 kPa	1.000 atm abs
1000 psig	12.00 ftH ₂ O	4000 mbar	1999 kPa	±1.000 atm
1999 psig	35.0 ftH ₂ O	1.000 bar abs	3500 kPa	1.000 atm
3000 psig	70.0 ftH ₂ O	1.000 bar vac	5000 kPa	4.00 atm
5000 psig	140.0 ftH ₂ O	±1.000 bar	3.50 MPa	7.00 atm
6.00 inHg	230 ftH ₂ O	1.000 bar	7.00 MPa	14.00 atm
10.00 inHg	480 ftH ₂ O	1.999 bar abs	14.00 MPa	19.99 atm
30.0 inHg abs	150.0 mmHg	1.999 bar	19.99 MPa	35.0 atm
30.0 inHg vac	260 mmHg	4.00 bar	35.0 MPa	70.0 atm
±30.0 inHg	760 mmHg abs	7.00 bar abs	1000 g/cm ² abs	135.0 atm
30.0 inHg	760 mmHg vac	7.00 bar	1000 g/cm ²	199.9 atm
60.0 inHg abs	760 mmHg	14.00 bar	2100 g/cm ² abs	340 atm
60.0 inHg	1600 mmHg abs	19.99 bar	2100 g/cm ²	

Accuracy (linearity, hysteresis, repeatability)

Standard: ±0.25% of full scale ±1 least significant digit

Optional: **-HA** ±0.1% FS ±1LSD (most ranges)

CD Factory calibration data

NC NIST traceable test report and calibration data

Display

3 readings per second nominal display update rate

Ranges up to 1999: 3½ digit LCD, 0.5" digit height

3000 psi, 5000 psi: 4½ digit LCD, 0.5" digit height, lower display for units

BBL models: Red LED backlight

Controls

B ranges up to 1999: Front pushbutton turns gauge on/off

BBL ranges up to 1999: Front pushbutton turns gauge & backlighting on/off

Front calibration potentiometers, non-interactive zero and span, ±10% range

B, BBL ranges of 3000 psi, 5000 psi

Front button turns gauge on, starts auto shutoff timer, and provides zero function for gauge reference ranges

Internal calibration pushbuttons

BBL ranges of 3000 psi, 5000 psi

Press button to activate backlighting for one minute while gauge is on

Auto Shutoff

5 minutes standard

Ranges up to 1999: Factory settable to 5, 10, 30 minutes, or on/off

3000 psi, 5000 psi: Factory settable to any number of minutes or hours

Batteries and Battery Life

Two AA alkaline

B ranges up to 1999: Approx. 2500 hours

B 3000 psi, 5000 psi: Approx. 2000 hours

BBL ranges up to 1999: Approx. 180 hours

BBL 3000 psi, 5000 psi: 150 to 1500 hrs depending on backlight usage

Low Battery Indication

Low battery symbol on display when batteries must be replaced

- ±0.25% Test Gauge Accuracy
- 316 Stainless Steel Wetted Parts
- Battery Life up to 2500 Hours
- Pressure, Vacuum, Absolute or Compound
- BBL Includes Backlit Display

DPG1000B100PSIG-5
0 to 100.0 psig range



DPG1000B5000PSIG-5
0 to 5000 psig range



Mechanical Specifications

Size

3.38" W x 2.88" H x 1.65" D housing

Add approximately 0.75" to height for pressure fitting

Weight

Gauge: 9 ounces (approx)

Shipping weight: 1 pound (approx)

Material and Color

Extruded aluminum case, epoxy powder coated

Polycarbonate cover, front and rear gaskets

Light gray body, light gray/blue front

Pressure/Vacuum Connection and Material

¼" NPT male, 316 stainless steel

Media Compatibility

All wetted parts are 316 SS

Compatible with most liquids and gases

Overpressure

3000 psig range and metric equivalents: 5000 psig

5000 psig range and metric equivalents: 7500 psig

3000 psi, 5000 psi: 112.5% out-of-range display

| - - - or | - . - . -

All others 2x rated pressure minimum

Burst Pressure

4x rated pressure minimum or 10,000 psi, whichever is less

Environmental

Storage Temperature -40 to 203°F (-40 to 95°C)

Operating Temperature -4 to 185°F (-20 to 85°C)

Compensated Temperature 32 to 158°F (0 to 70°C)



RB Rubber Boot
Not for NEMA 4X models

Cecomp Electronics

cecomp.com



INSTALLATION AND PRECAUTIONS

Install or remove gauge using wrench on hex fitting only. Do not attempt to tighten by turning housing or any other part of the gauge. Use fittings appropriate for the pressure range of the gauge. Do not apply vacuum to gauges not designed for vacuum operation.

Due to the hardness of 316 stainless steel, it is recommended that a thread sealant be used to ensure leak-free operation.

NEVER insert objects into the gauge port or blow out with compressed air. Permanent damage not covered by warranty will result to the sensor.

OPERATION - RANGES UP TO 1999

Press the round button on the front of the gauge to activate the display. The gauge will stay on for a period of time determined by the auto-shutoff time. The gauge can be shut off at any time by pressing the button again. Display backlighting on DPG1000BBL models is on whenever the gauge is on. If the gauge was ordered without auto shutoff it will stay on until the button is pressed or until the batteries are depleted. Turn gauge off when not in use to conserve battery.

OPERATION - 3000 PSI, 5000 PSI RANGES

Press and hold the pushbutton for approx. 1 second. The full-scale range is indicated, display segments are tested, and the reading and units are displayed.

Power-Up With One-Touch Zero (Gauge reference models only)

1. Make absolutely certain no pressure is applied to the gauge. The gauge port should be exposed to normal atmospheric pressure. Note that the zeroing function may only be activated at power-up and the stored zero correction is erased when the gauge is shut off.
2. Press and hold the pushbutton.
3. The full-scale range is indicated and the display segments are tested.
4. Continue to press the pushbutton until **0 0 0 0** is displayed and then release the button. This indicates that the gauge has been zeroed.
5. The actual pressure is displayed.

Attempting to zero the gauge with pressure greater than approximately 3% of full-scale applied will result in an error condition, and the display will alternately indicate **E r r 0** and the actual measured pressure. The gauge must be powered down to reset the error condition.

Absolute reference gauges do not use the zero feature since they read atmospheric pressure under normal conditions.

Normal Operation

Following the start-up initialization, the display indicates the pressure reading updated approximately 3 times per second and the units. The auto shutoff timer starts when the gauge is powered up or whenever the button is pushed, unless the gauge was ordered without an auto shutoff time (-ON option).

If excessive vacuum is applied to a pressure-only gauge, the display will indicate **- E r r** until the vacuum is released. Applying vacuum to a gauge designed for pressure may damage the pressure sensor. If excessive pressure is applied (112.5% over range), an out-of-range indication of **l - - -** or **l -.-.-** will be displayed depending on model.

Display Backlighting (BBL models only)

Display backlighting can be turned on by momentarily pressing the button whenever the gauge is on. The backlighting will turn on for one minute and then automatically shut off. This also restarts the auto shutoff timer.

Shut-Down

To shut off the gauge manually at any time, press and hold the pushbutton until the display indicates **0 F F** (about 5 seconds) and then release.

For gauges with auto shutoff, the display indicates **0 F F** five seconds prior to auto shutoff. The pushbutton can be pressed to keep the gauge on. The auto shutoff and backlight (if equipped) timers are reset whenever the pushbutton is pressed and released.

If the gauge was ordered without auto shutoff (-ON option) it will stay on until manually shut off or until the batteries are depleted. Turn gauge off when not in use to conserve battery life.

CALIBRATION

All Falcon gauges are factory calibrated on NIST traceable calibration equipment. No calibration is required before placing the gauge into service.

Ranges up to 1999: Remove the calibration potentiometer covers on the front of the unit to access the zero and span controls. Gauge reference units may be re-zeroed without affecting the span calibration. The gauge port must be open to the ambient with no pressure or vacuum applied. Adjust the Zero control until the gauge reads zero with the minus (-) sign occasionally flashing.

CALIBRATION (CONTINUED)

Span calibration should only be attempted if the user has access to a pressure reference of known accuracy. The quality of the calibration is only as good as the accuracy of the calibration equipment and ideally should be at least four times the gauge accuracy. Zero calibration must be done before span calibration. Record readings at three to five points over the range of gauge and adjust span control to minimize error and meet specifications.

3000 psi and 5000 psi ranges – The calibration adjustments are internal on these models. The procedure is available from cecomp.com or by calling to request the "F16" calibration instructions.

Absolute Reference – These models display atmospheric pressure if the gauge port is open to the ambient. It is normal for the reading to constantly change in response to atmospheric pressure changes. Vacuum generation and atmospheric pressure measurement equipment for accurate calibration and thus these are more difficult to calibrate in the field.

Gauges can be returned to Cecomp Electronics for factory certified recalibration, repairs and refurbishment. NIST traceability is available. Gauges can also be recalibrated by any metrology lab with pressure calibration equipment at least four times more accurate than the gauge.

BATTERY REPLACEMENT

A low battery indication will be shown in the upper left-hand corner of the display when the battery voltage falls sufficiently. The battery should be replaced soon after the indicator comes on or unreliable readings may result.

Remove the 6 Phillips head screws on the back of the unit.

Carefully remove batteries from the holders by lifting up the positive end of the battery (opposite the spring). Take care not to bend or distort the battery retention springs.

DO NOT discard the old battery into fire, any other sources of extreme heat, or in any other hazardous manner. Please consult local authorities if there is any question about proper disposal.

Always replace both batteries at the same time with high quality alkaline batteries. Observe the polarity of the batteries when replacing them. The negative (flat) end of each battery should be inserted first, and should face the spring in the battery holder.

Replace the back cover, including the rubber sealing gasket.

DIMENSIONS

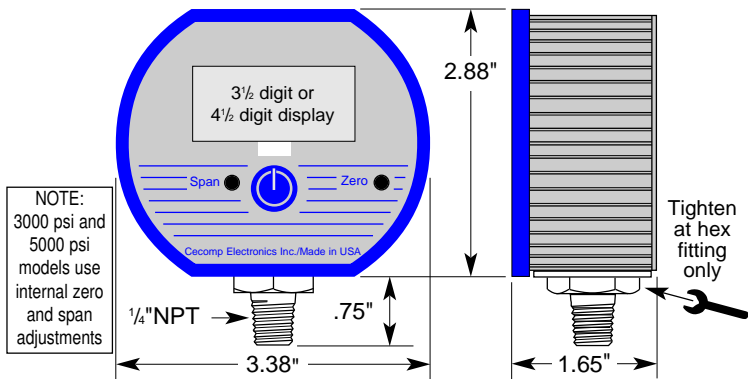

PART NUMBERS

DPG1000B range units reference - shutoff

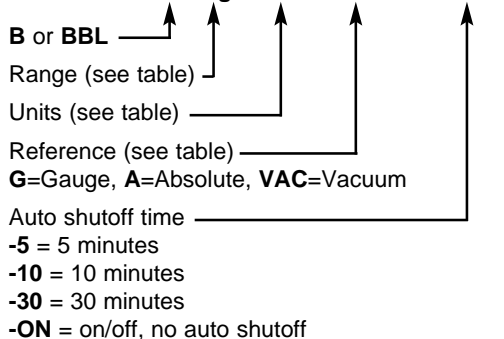

Unit Abbreviations

psi	= PSI
inHg	= INHG
oz/in ²	= ZIN
inH ₂ O	= INH2O
ftH ₂ O	= FTH2O
mmHg	= MMHG
torr	= TORR
mmH ₂ O	= MMH2O
kg/cm ²	= KGCM
g/cm ²	= GCM
kPa	= KPA
MPa	= MPA
mbar	= MBAR
bar	= BAR
cmH ₂ O	= CMH2O
atm	= ATM

Cecomp maintains a constant effort to upgrade and improve its products. Specifications are subject to change without notice. Consult factory for your specific requirements.

Example: DPG1000B100PSIG-5 = Battery powered, 100.0 psig, 5 minute shutoff